

Rotor head

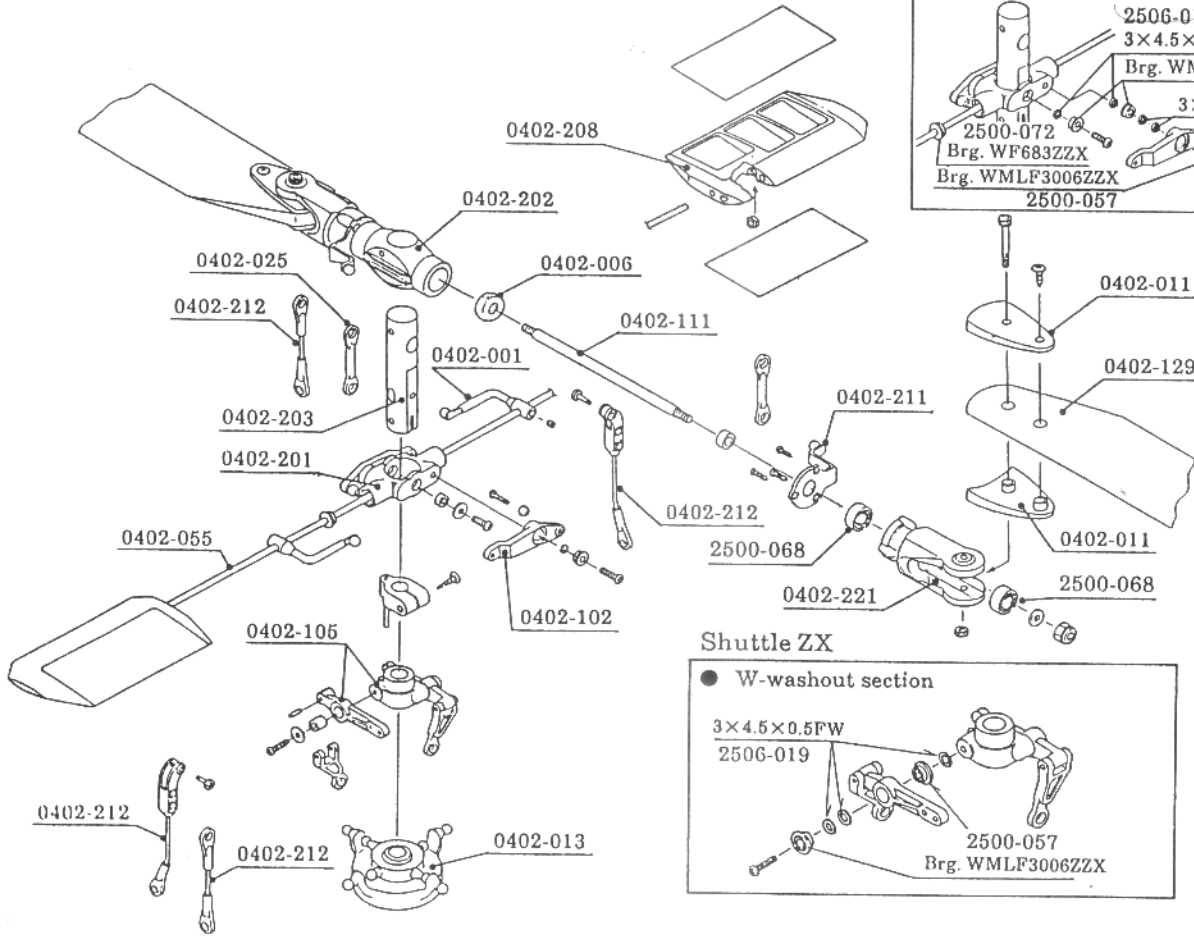

Code No.	Name of parts	Quantity	Japanese retail price (¥)	Remarks	30 Lama	NS Shuttle	Shuttle XX	Shuttle Z	Shuttle ZX
0402-001	Stabilizer control arm	2	600	With $\phi 5$ ball and screw		○	○	○	○
0402-006	Damper rubber	4	400			○	○	○	○
0408-051	Damper rubber (soft type)	4	400			○	○	○	○
0402-221	Blade holder set	2	1,200			○	○	○	○
0402-211	Pitch arm	2	600	With $\phi 5$ ball and screw				○	○
0402-011	Root end (A) (B)	2 for each	600	With screw		○	○	○	○
0402-013	Swash plate assembly	1	2,000			○	○	○	○
0402-140	$\phi 8$ coaxial swash plate	1	6,800			○	○	○	○
0402-208	Stabilizer blade	2	1,200	With M3 nut		○	○	○	○
0402-055	Stabilizer bar	2	800			○	○	○	○
0402-129	Main blade L = 550	2	2,900	With weight Use with belt and pipe		△	△	○	○
0402-234	Symmetrical main blade L = 550	2	3,800	With weight		△	△	○	○
0402-201	ZS seesaw	1	700	With FW, screw and metal				○	○
0402-102	NS mixing arm	2	600	With $\phi 5$ ball, FW, metal and screw		○	○	○	○
0402-203	ZS center hub	1	1,000					○	○
0402-202	ZS yoke	1	700					○	○
0402-105	NS wash-out	1 set	1,400			○	○	○	○
0402-233	SE W-type wash-out	1	6,800			○	○	○	○
0402-111	NS feathering spindle	1	600	With collar		○	○	○	○
0402-269	SE feathering spindle	1	900			○	○	○	○
0402-212	ZS linkage set	1	500	For rotor head				○	○
0402-214	FZ rotor head assembly	1	6,500	Without stabilizer blade and bar		△	△	○	○
0402-242	SZ rotor head assembly	1	23,800			△	△	○	○
0402-123	Shuttle XX bearing set	18	8,500	With collar and washer		○	○	○	○
2500-068	Bearing $\phi 5 \times \phi 13 \times 4$ ZZ	2	1,200	Support blade holder		○	○	○	○

Main frame

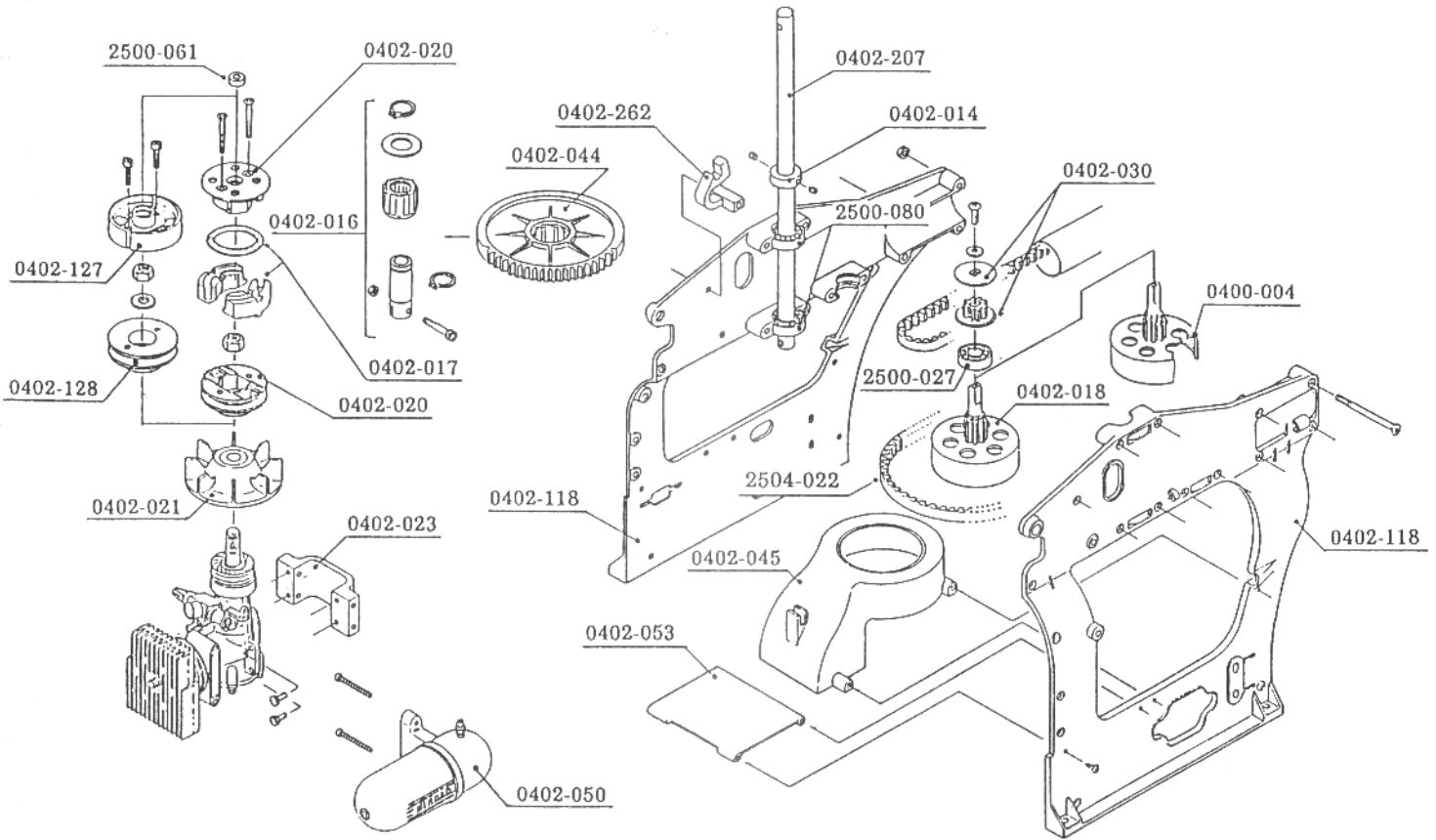

Code No.	Name of parts	Quantity	Japanese retail price (¥)	Remarks	30 Lama	NS Shuttle	Shuttle XX	Shuttle Z	Shuttle ZX
0402-262	Cabin lock	1	300			○	○	○	○
0402-014	Mast lock φ8	1	300			○	○	○	○
0402-016	Auto-rotation clutch set	1 set	3,000	With bearing, bushing, drive shaft and stop ring		○	○	○	○
0402-017	Clutch set	1 set	800	With clutch shoe, clutch spring and screw		○	○	○	
0402-126	SE clutch set	1	3,800			○	○	○	○
0402-127	SE clutch shoe	1	2,200			△	△	△	○
0402-128	SE starter pulley	1	1,800			△	△	△	○
0402-018	1st shaft spar gear with bell	1	1,500			○	○	○	○
0402-230	SE clutch bell	1	3,800			△	△	△	○
0402-020	Starter pulley	1	700	With clutch housing and screw		○	○	○	
0402-021	Cooling fan	1	700			○	○	○	○
0402-023	28-32 engine mount	1	1,400	With FW and screw		○	○	○	○
0402-030	Timing pulley 8T	1	400	With flange, FW and screw		○	○	○	○
0402-044	Main gear	1	700			○	○	○	○
0402-243	SE main gear 77T	1	6,800			○	○	○	○
0402-045	Cooling cover	1	700			○	○	○	○
2504-022	Starter belt L=400	1	600			○	○	○	○
0402-050	Muffler set	1	2,000	With screw		○	○	○	○
0402-248	SE muffler	1	4,800			○	○	○	○
0402-207	ZS main mast	2	1,000					○	○
0402-268	SE main mast	1	1,200					○	○
0402-118	NS main frame set (R) (L)	1 for each	2,000	With screw		○	○	○	○
2500-027	Bearing φ6×φ17×6 ZZ	2	1,200			○	○	○	○
2500-080	Bearing φ8×φ19×6 ZZ	2	1,200	Used in main mast		○	○	○	○
2500-061	Bearing φ4×φ9×4 ZZ	2	1,200	Used in clutch		○	○	○	○
0400-004	Metal made clutch bell lining	2	200	Used in Shuttle SE clutch		△	△	△	○

Front frame

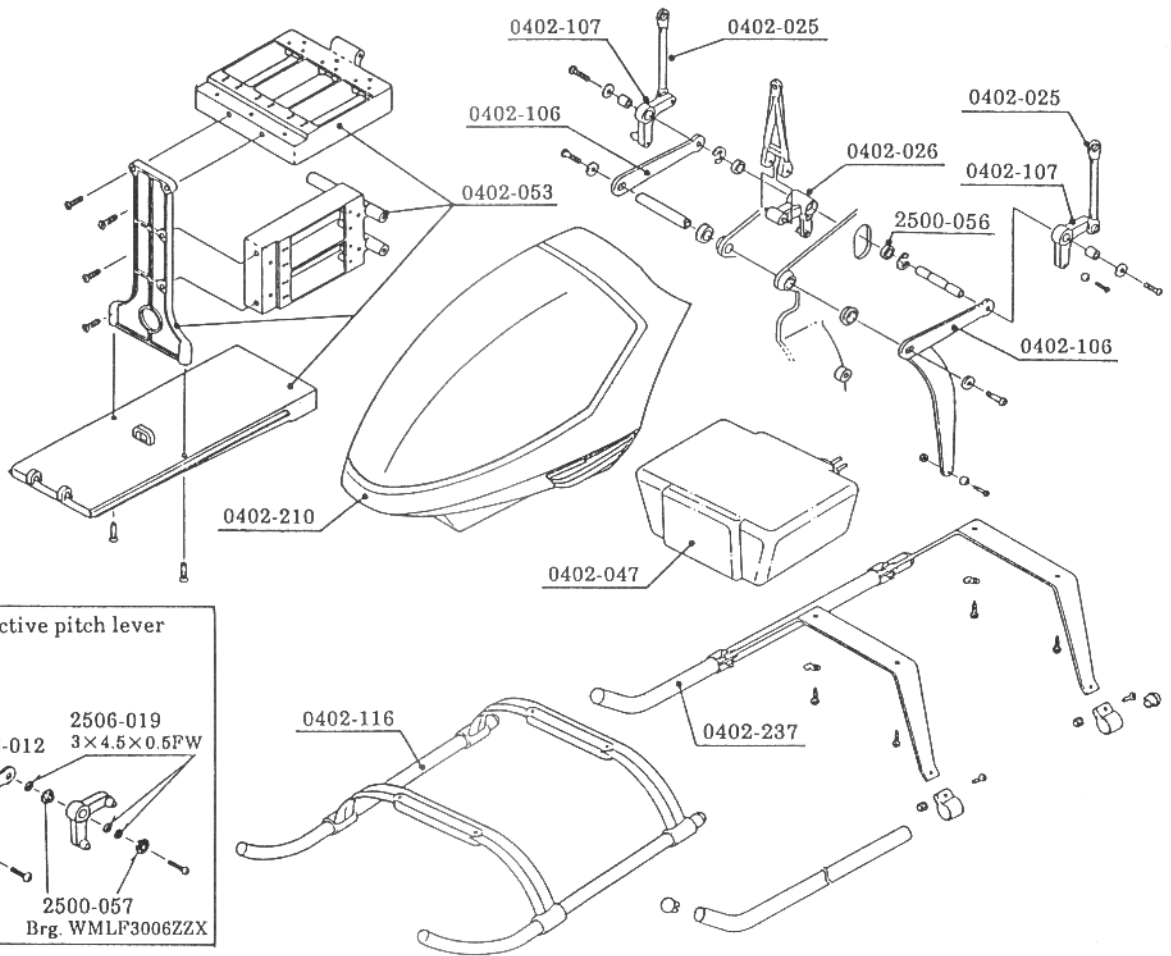

Shuttle ZX

● Aileron lever, Collective pitch lever section

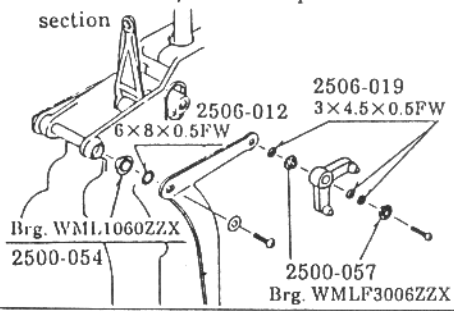

Code No.	Name of parts	Quantity	Japanese retail price (¥)	Remarks	30 Lama	NS Shuttle	Shuttle XX	Shuttle Z	Shuttle ZX
0402-025	Double link set	5	600	A = 30×2, B = 53×2, C = 60×1		○	○	○	○
0402-026	Elevator lever set	1 set	600	Shaft, lever, A-type rod and needle pin		○	○	○	○
0402-047	Fuel tank set	1 set	900	230CC		○	○	○	○
0402-053	Servo mount set	1 set	2,000	A, B, front frame and gyro mount		○	○	○	○
0402-106	NS collective pitch lever (L) set	1 set	900	With lever, lever (L), shaft, FW and screw		○	○	○	○
0402-107	NS aileron lever set	2	600	With L-type crank, ø5 ball, bushing, FW and screw		○	○	○	○
0402-239	SE L-type lever	1	1,800			○	○	○	○
0402-110	NS linkage set (B)	1 set	900	Pitch up portion		○	○	○	○
0402-213	ZS instruction manual	1	600					○	○
0402-209	ZS transcribing mark (blue/black)	1	1,000					○	○
0402-229	ZS transcribing mark (pink/gray)	1	1,000					○	○
0402-210	ZS cabin set (White)	1	3,000			○	○	○	○
0402-220	GP landing gear	1	2,000			○	○	○	○
0402-237	SE landing gear	1	3,500			○	○	○	○
2500-057	Bearing ø3×ø6×2.5F ZZ	2	1,200	Aileron lever portion		○	○	○	○
2506-019	FW 3×4.5×0.5T	10	200	Aileron lever portion		○	○	○	○
2500-054	Bearing WML1060ZZX	2	1,200	Bearing ø6×10×3 ZZ		○	○	○	○
2513-001	Wrench set	1 set	400	L-type wrench×2 Plug wrench×1		○	○	○	○

Tail

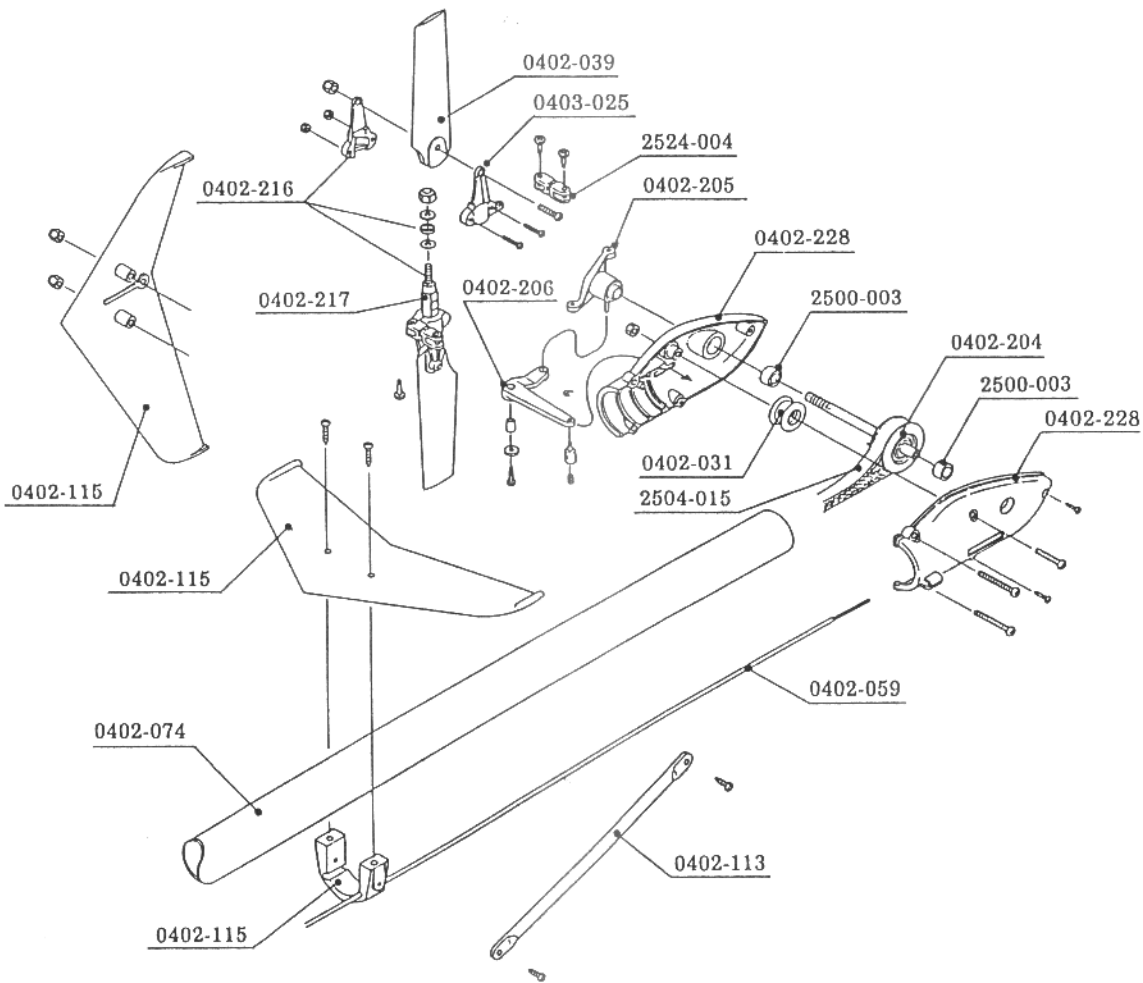

Code No.	Name of parts	Quantity	Japanese retail price (¥)	Remarks	30 Lama	NS Shuttle	Shuttle XX	Shuttle Z	Shuttle ZX
0402-031	Guide pulley (With bearing)	1	800			○	○	○	○
0402-235	SE guide pulley	1	1,000			○	○	○	○
0402-204	Tail drive shaft (With pulley)	1	800					○	○
0402-206	Tail pitch lever set	1	400	With screw		○	○	○	○
0402-039	Tail blade	2	500			○	○	○	○
0402-048	Tail unit case (R) (L)	1 for each	700	With screw		○	○	○	○
0402-228	ZS tail unit case (R) (L)	1 for each	800	Open type		○	○	○	○
0402-074	Tail boom L=617	1	1,000	For long tail		△	△	○	○
0402-236	SE tail boom	1	1,200			△	△	○	○
0402-059	Rudder control shaft set	1	400	With pipe		○	○	○	○
0402-216	Tail housing assembly	1	2,500	With bearing blade holder				○	○
0402-217	ZS tail housing	1	600					○	○
0402-205	ZS tail pitch plate set	1	1,600					○	○
0402-113	NS tail boom brace	2	800			○	○	○	○
0402-238	SE tail boom brace	2	1,000			○	○	○	○
0402-115	NS stabilizer set (White)	1 set	900			○	○	○	○
2500-003	Bearing $\phi 5 \times \phi 11 \times 5$ ZZ	2	1,200	Support tail shaft		○	○	○	○
2524-004	Double link pin type	2	300			○	○	○	○
2504-015	Timing belt 564XL020	1	1,700	For long tail		△	△	○	○